

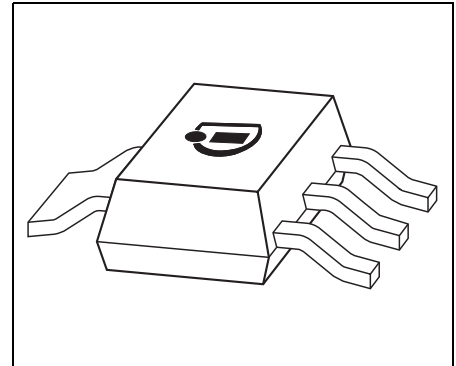

Features

- Fixed output voltage 5.0 V or 3.3 V
- Output voltage tolerance $\leq \pm 2\%$, $\pm 3\%$
- 150 mA current capability
- Very low current consumption
- Low-drop voltage
- Overtemperature protection
- Reverse polarity proof
- Wide temperature range
- Suitable for use in automotive electronics
- Inhibit
- Green Product (RoHS compliant)
- AEC Qualified



Functional Description

The TLE 4266-2 is a monolithic integrated low-drop fixed voltage regulator which can supply loads up to 150 mA. It can be switched on and off by the $\overline{\text{INH}}$ pin. It is functional compatible to the TLE 4266, but with a reduced quiescent current of $\ll 1 \mu\text{A}$ in OFF mode and $40 \mu\text{A}$ in ON mode. The TLE 4266-2 is especially designed for all applications that require very low quiescent current in ON and OFF mode. The device is available in the small surface mounted PG-SOT223-4-11 package. It is pin compatible to the TLE 4266 G. It is designed to supply microprocessor systems under the severe condition of automotive applications and therefore it is equipped with additional protection against over load, short circuit and overtemperature. Of course the TLE 4266-2 can be used in other applications, where a stabilized voltage and the inhibit feature is required.

And input voltage V_I up to 45 V is regulated to $V_O = 5 \text{ V}$ (TLE 4266-2 G) or $V_O = 3.3 \text{ V}$ (TLE 4266-2 GSV33) with an accuracy of $\pm 3\%$. For the 5 V device an accuracy of $\pm 2\%$ is kept for a load current range up to 50 mA.

The device operates in the temperature range of $T_j = -40$ to $150 \text{ }^\circ\text{C}$. A High level at the $\overline{\text{INH}}$ pin switches the regulator on.

Type	Package
TLE 4266-2 G	PG-SOT223-4-11
TLE 4266-2 GSV33	PG-SOT223-4-11

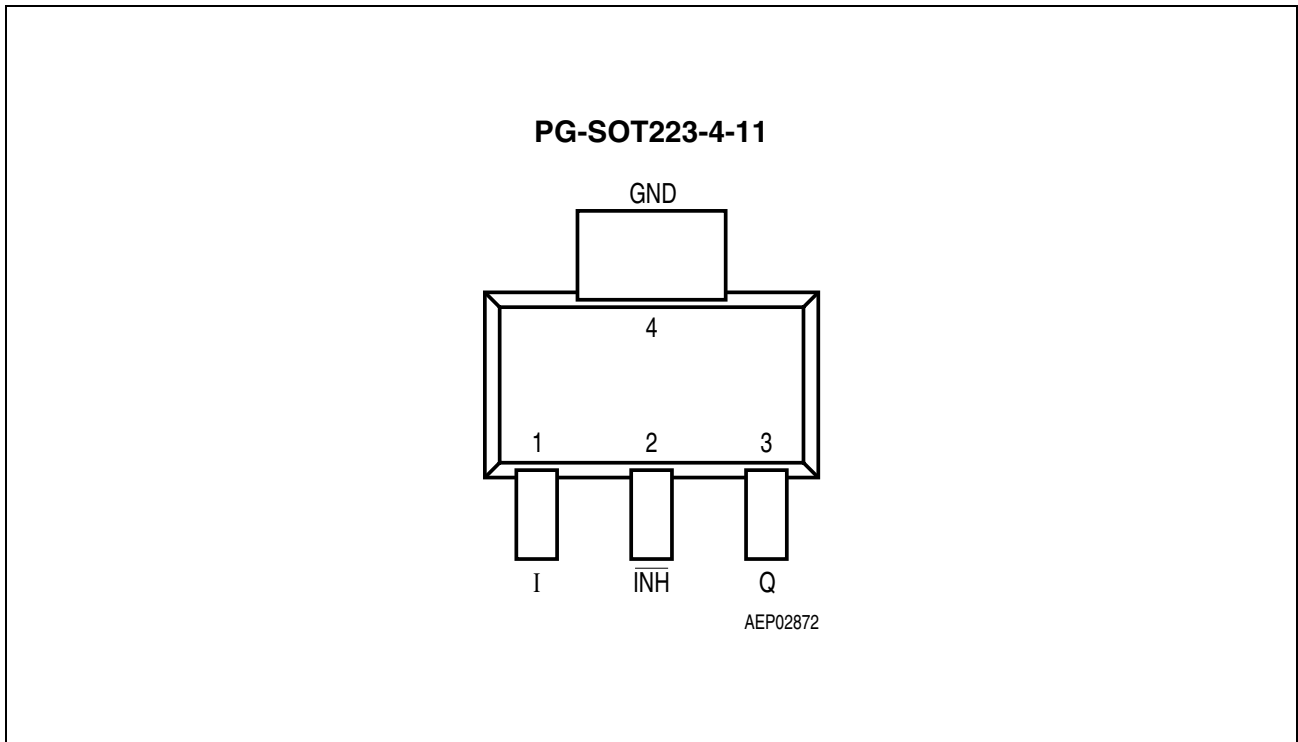

Figure 1 Pin Configuration (top view)

Table 1 Pin Definitions and Functions TLE 4266-2 G, TLE 4266-2 GSV33

Pin	Symbol	Function
1	I	Input voltage; block to ground directly at the IC with a ceramic capacitor.
2	$\overline{\text{INH}}$	Inhibit input; high level turns IC on, integrated pull-down resistor.
3	Q	Output voltage; block to ground with a capacitor $C_Q \geq 10 \mu\text{F}$, $\text{ESR} \leq 4 \Omega$
4	GND	Ground

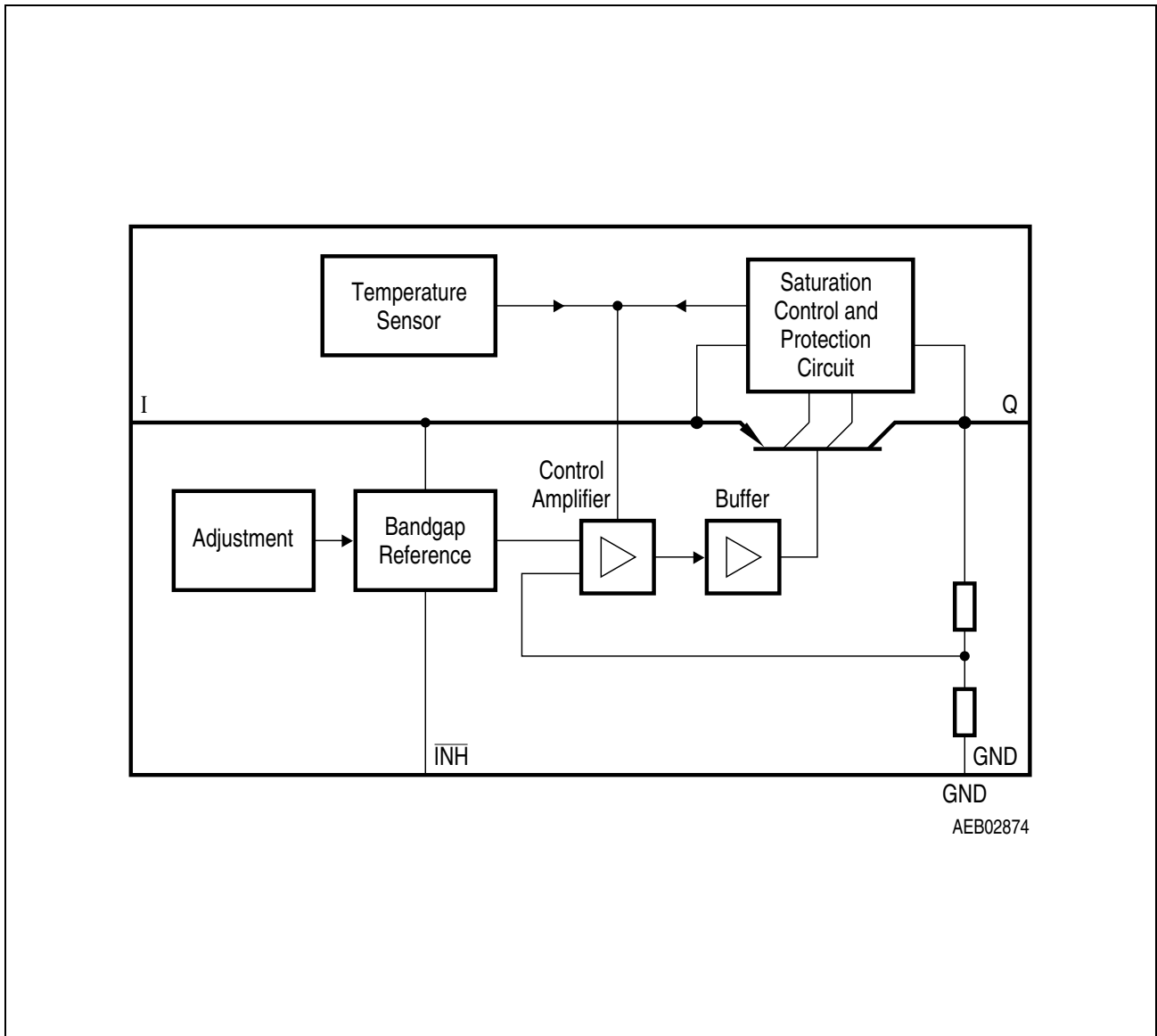

Figure 2 **Block Diagram**

Table 2 Absolute Maximum Ratings
 $T_j = -40$ to 150 °C

Parameter	Symbol	Limit Values		Unit	Notes
		Min.	Max.		
Input I					
Voltage	V_I	-42	45	V	–
Current	I_I	–	–	–	internally limited
Inhibit \overline{INH}					
Voltage	$V_{\overline{INH}}$	-42	45	V	–
Output Q					
Voltage	V_Q	-0.3	32	V	–
Current	I_Q	–	–	–	internally limited
GND					
Current	I_{GND}	50	–	mA	–
Temperature					
Junction temperature	T_j	–	150	°C	–
Storage temperature	T_S	-50	150	°C	–
Thermal Resistance					
Junction ambient	R_{thj-a}	–	81	K/W	PG-SOT223-4-11 ¹⁾
Junction case	$R_{thj-pin4}$	–	18	K/W	PG-SOT223-4-11
Operating Range					
Input voltage	V_I	5.5	45	V	TLE 4266-2 G
		4.4	45	V	TLE 4266-2 GSV33
Junction temperature	T_j	-40	150	°C	–

1) Worst case, regarding peak temperature; zero airflow; mounted on a PCB $80 \times 80 \times 1.5$ mm³, heat sink area 300 mm².

Table 3 Characteristics
 $V_I = 13.5 \text{ V}; V_{\text{INH}} = 5 \text{ V}; -40 \text{ }^\circ\text{C} \leq T_j \leq 125 \text{ }^\circ\text{C}$ unless otherwise specified

Parameter	Symbol	Limit Values			Unit	Test Condition
		Min.	Typ.	Max.		
Output voltage	V_Q	4.85	5.0	5.15	V	TLE 4266-2 G; $5 \text{ mA} \leq I_Q \leq 100 \text{ mA};$ $6 \text{ V} \leq V_I \leq 21 \text{ V}$
		4.9	5.0	5.1	V	TLE 4266-2 G; $5 \text{ mA} \leq I_Q \leq 50 \text{ mA};$ $9 \text{ V} \leq V_I \leq 16 \text{ V}$
Output voltage	V_Q	3.20	3.30	3.40	V	TLE 4266-2 GSV33; $5 \text{ mA} \leq I_Q \leq 100 \text{ mA};$ $6 \text{ V} \leq V_I \leq 21 \text{ V}$
Output-current limitation	I_Q	150	200	500	mA	–
Current consumption $I_q = I_I - I_Q$	I_q	–	0	1	μA	$V_{\text{INH}} = 0 \text{ V}; T_j \leq 100 \text{ }^\circ\text{C}$
Current consumption $I_q = I_I - I_Q$	I_q	–	40	60	μA	$I_Q = 100 \mu\text{A};$ $T_j \leq 85 \text{ }^\circ\text{C}$
		–	40	70	μA	$I_Q = 100 \mu\text{A}$
Current consumption $I_q = I_I - I_Q$	I_q	–	1.7	4	mA	$I_Q = 50 \text{ mA}$
Drop voltage	V_{Dr}	–	0.25	0.5	V	TLE 4266-2 G; $I_Q = 100 \text{ mA}^1)$
Drop voltage	V_{Dr}	–	1.00	1.10	V	TLE 4266-2 GSV33; $I_Q = 100 \text{ mA}^2)$
Load regulation	ΔV_Q	–	50	90	mV	TLE 4266-2 G; $I_Q = 1 \text{ to } 100 \text{ mA};$ $V_I = 6 \text{ V}$
Load regulation	ΔV_Q	–	35	60	mV	TLE 4266-2 GSV33; $I_Q = 1 \text{ to } 100 \text{ mA};$ $V_I = 6 \text{ V}$
Line regulation	ΔV_Q	–	5	30	mV	TLE 4266-2 G; $V_I = 6 \text{ V to } 28 \text{ V};$ $I_Q = 1 \text{ mA}$
Line regulation	ΔV_Q	–	4	20	mV	TLE 4266-2 GSV33; $V_I = 6 \text{ V to } 28 \text{ V};$ $I_Q = 1 \text{ mA}$

Table 3 Characteristics (cont'd)
 $V_I = 13.5 \text{ V}; V_{\text{INH}} = 5 \text{ V}; -40 \text{ }^\circ\text{C} \leq T_j \leq 125 \text{ }^\circ\text{C}$ unless otherwise specified

Parameter	Symbol	Limit Values			Unit	Test Condition
		Min.	Typ.	Max.		
Power Supply Ripple Rejection	$PSRR$	–	68	–	dB	$f_r = 100 \text{ Hz};$ $V_r = 0.5 \text{ Vpp}$
Output Capacitor	C_Q	10	–	–	μF	$\text{ESR} \leq 4 \text{ } \Omega$ at 10 kHz

Inhibit

Inhibit on voltage	$V_{\text{INH, on}}$	3.5	–	–	V	–
Inhibit off voltage	$V_{\text{INH, off}}$	–	–	0.8	V	–
Inhibit current	I_{INH}	–	4	8	μA	$V_{\text{INH}} = 5 \text{ V}$
Pull-down resistor	R_{INH}	–	1.0	–	$\text{M}\Omega$	see I_{INH}

- 1) Drop voltage = $V_I - V_Q$ (measured when the output voltage V_Q has dropped 100 mV from the nominal value obtained at $V_I = 13.5 \text{ V}$).
- 2) Drop voltage = $V_I - V_Q$ (measured when the output voltage V_Q has dropped 100 mV from the nominal value obtained at $V_I = 13.5 \text{ V}$).

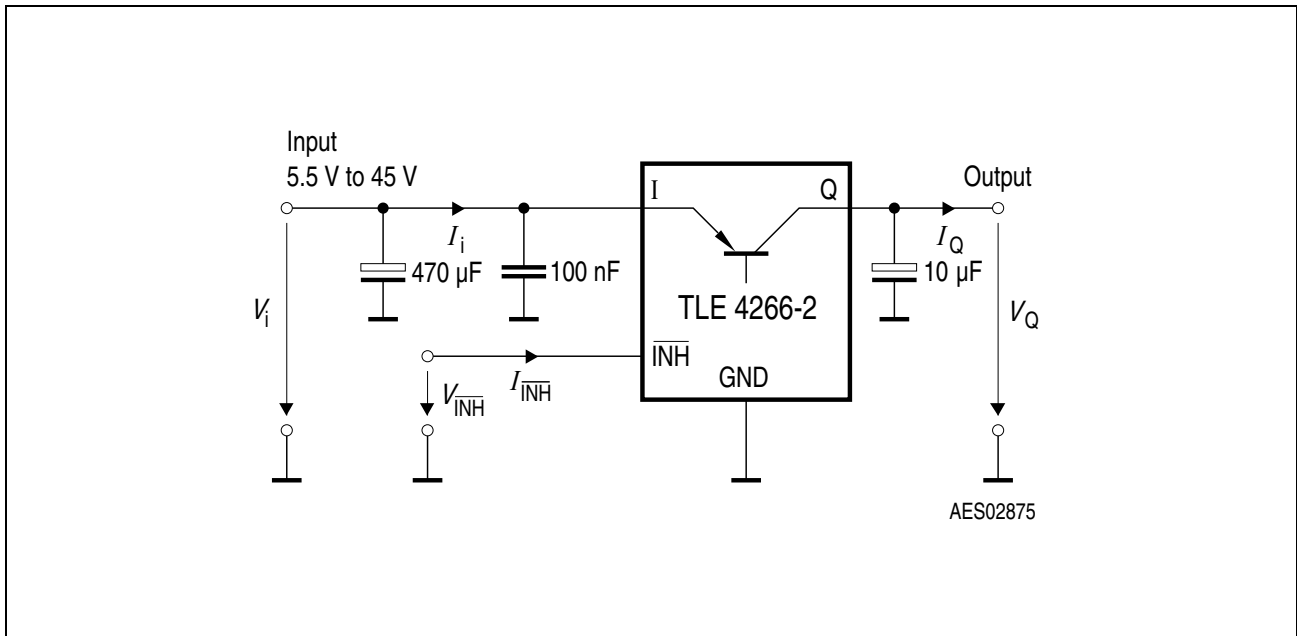

Figure 3 Measuring Circuit

Circuit Description and Application Information

In the TLE 4266-2 the output voltage is divided and compared to an internal reference of 2.5 V typical. The regulation loop controls the output to achieve an output voltage of 5 V with an accuracy of $\pm 2\%$ at an input voltage up to 45 V. The minimum required input voltage is $V_Q + V_{dr}$ with a drop voltage V_{dr} of max. 0.5 V (see **“Typical Performance Characteristics”** on Page 8) in case of the TLE 4266-2 G. The TLE 4266-2 GSV33 requires a minimum input voltage of 4.4 V.

The TLE 4266-2 can supply up to 150 mA. However for protection reasons at high input voltage above 25 V, the maximum output current is reduced (SOA protection).

Figure 3 shows a typical measuring circuit. For stability of the control loop the TLE 4266-2 output requires an output capacitor C_Q of at least 10 μF with a maximum permissible ESR of 4 Ω . Tantalum as well as multi layer ceramic capacitors are suitable.

At the input of the regulator an input capacitor is necessary for compensating line influences (100 nF ceramic capacitor recommended). A resistor of approx. 1 Ω in series with C_I , can damp any oscillation occurring due the input inductivity and the input capacitor. In the measuring circuit shown in **Figure 3** an additional electrolytic input capacitor of 470 μF is added in order to buffer supply line influences. This capacitor is recommended, if the device is sourced via long supply lines of several meters.

The TLE 4266-2 includes the Inhibit function. For a voltage above 3.5 V at the $\overline{\text{INH}}$ pin the regulator is switched on.

Typical Performance Characteristics

Output Voltage V_Q versus Junction Temperature T_j

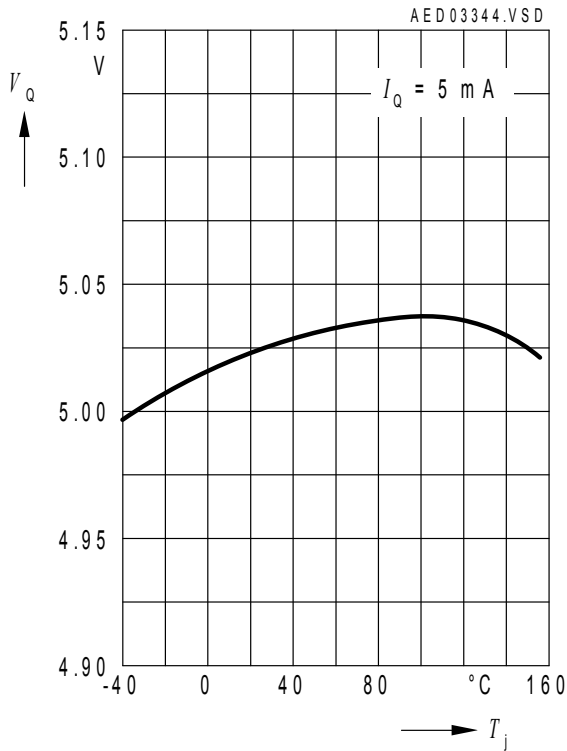

Drop Voltage V_{dr} versus Output Current I_Q (TLE 4266-2 G)

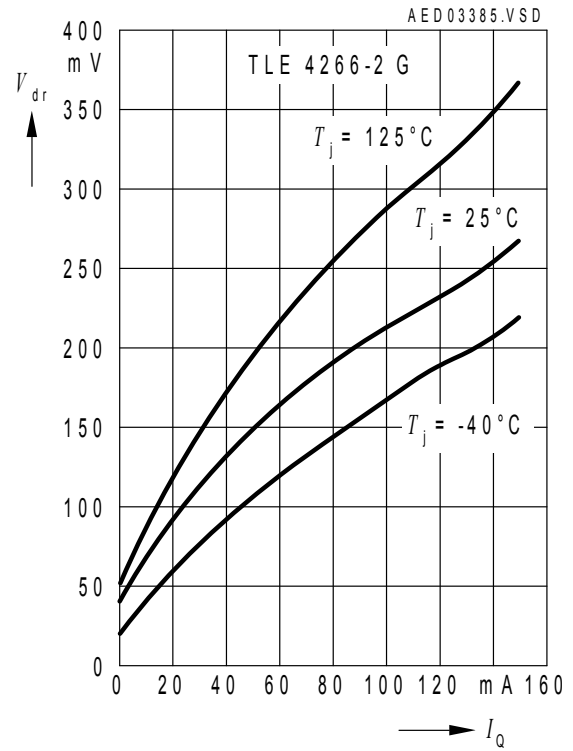

Output Voltage V_Q versus Input Voltage V_I

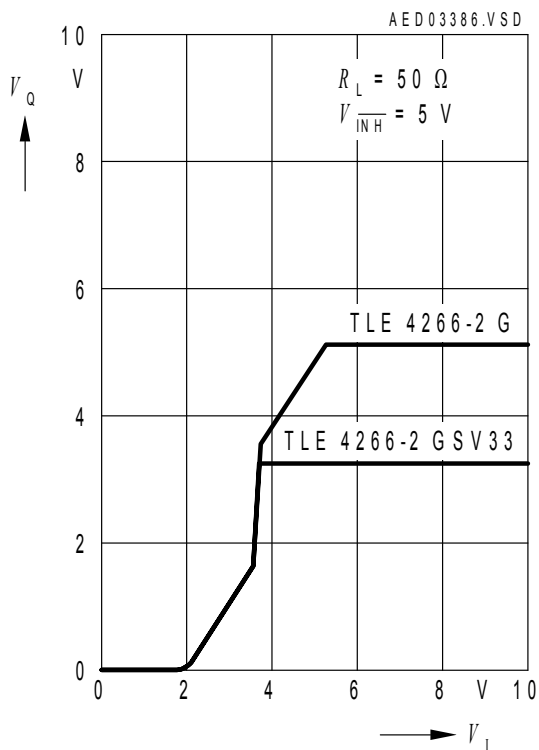

Inhibit Current I_{INH} versus Inhibit Voltage V_{INH}

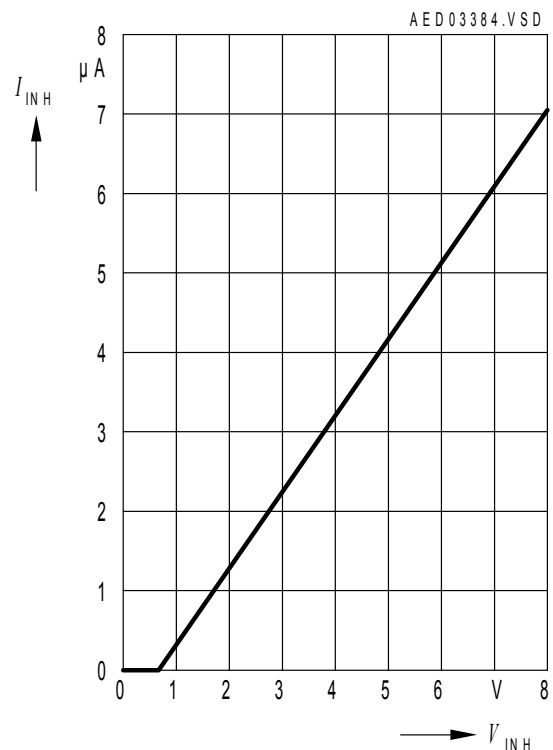

Current Consumption I_q versus Output Current I_Q

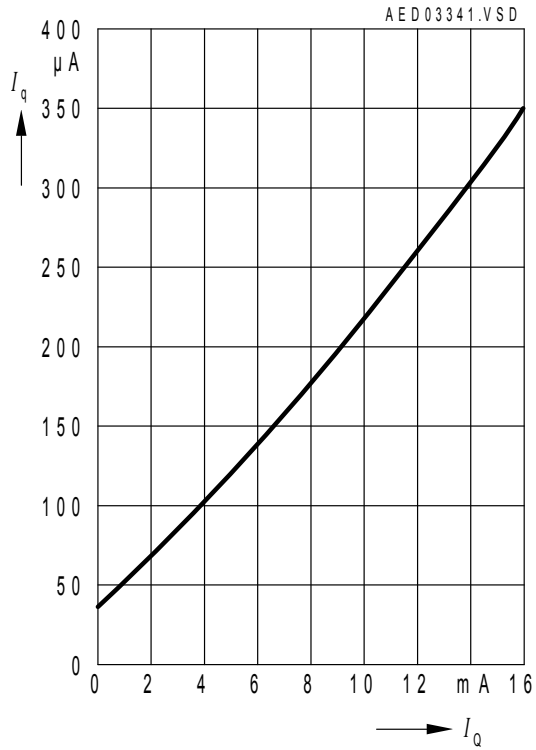

Current Consumption I_q versus Output Current I_Q

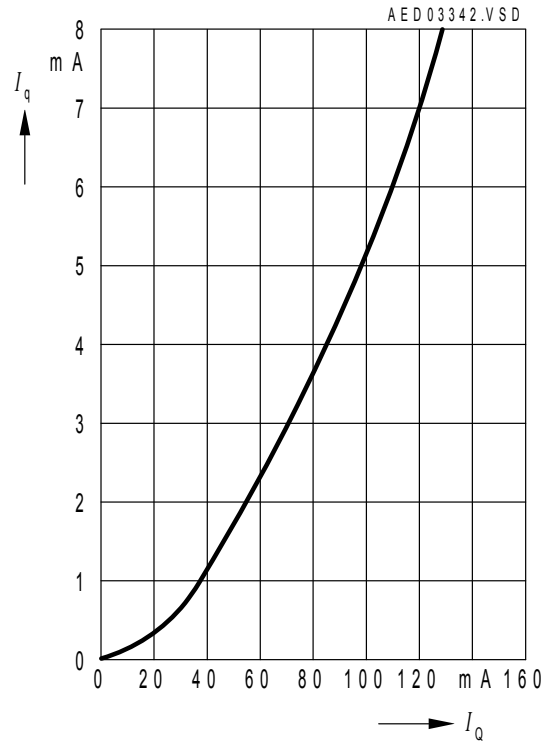

Package Outlines

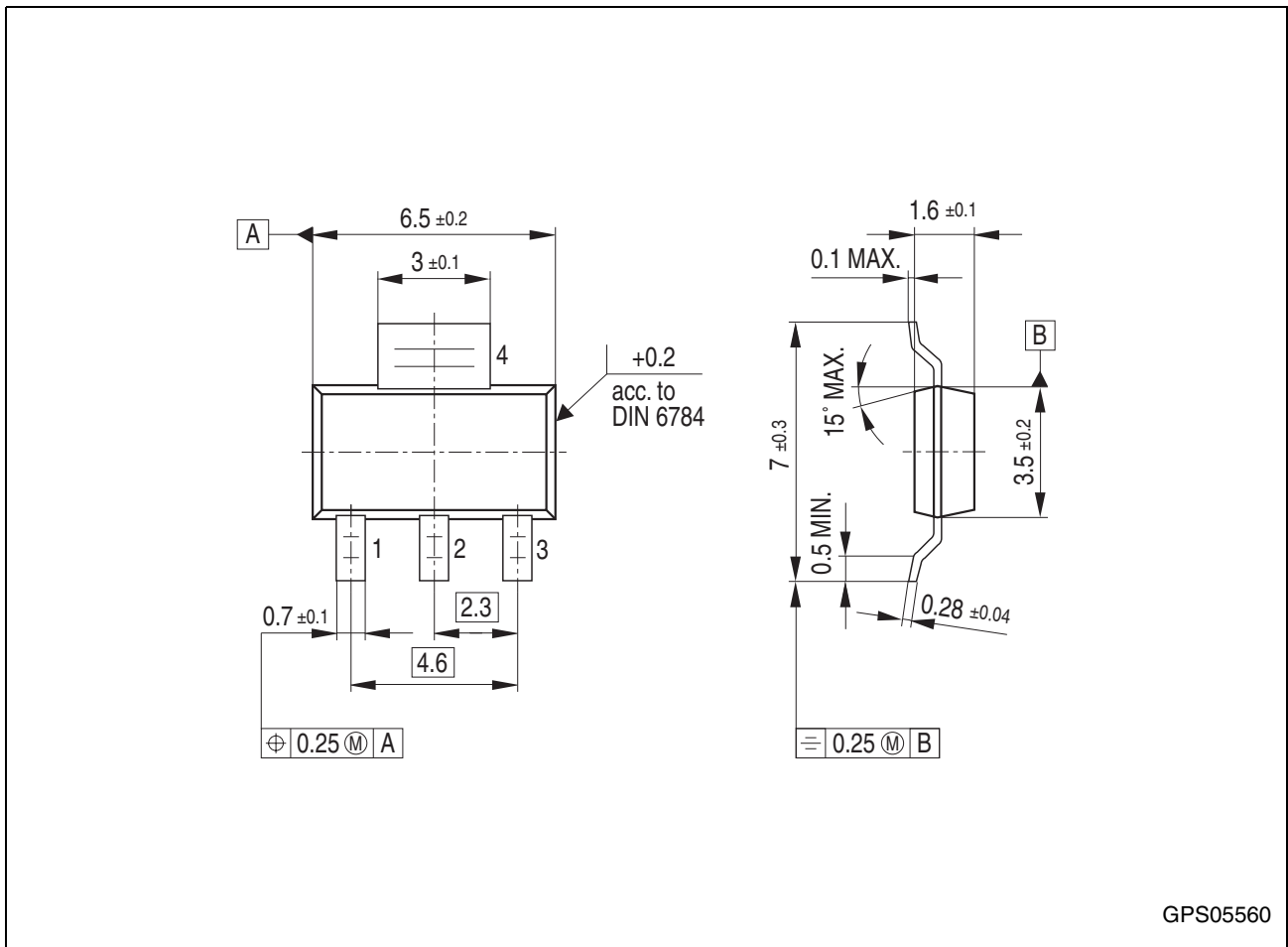

GPS05560

Figure 4 PG-SOT223-4-11 (Plastic Small Outline Transistor)

Green Product (RoHS compliant)

To meet the world-wide customer requirements for environmentally friendly products and to be compliant with government regulations the device is available as a green product. Green products are RoHS-Compliant (i.e Pb-free finish on leads and suitable for Pb-free soldering according to IPC/JEDEC J-STD-020).

You can find all of our packages, sorts of packing and others in our Infineon Internet Page “Products”: <http://www.infineon.com/products>.

SMD = Surface Mounted Device

Dimensions in mm

Revision History

Version	Date	Changes
Rev. 1.3	2007-03-20	Initial version of RoHS-compliant derivate of TLE 4266-2 Page 1 : AEC certified statement added Page 1 and Page 10 : RoHS compliance statement and Green product feature added Page 1 and Page 10 : Package changed to RoHS compliant version Legal Disclaimer updated

Edition 2007-03-20

**Published by
Infineon Technologies AG
81726 Munich, Germany**

**© 2007 Infineon Technologies AG
All Rights Reserved.**

Legal Disclaimer

The information given in this document shall in no event be regarded as a guarantee of conditions or characteristics. With respect to any examples or hints given herein, any typical values stated herein and/or any information regarding the application of the device, Infineon Technologies hereby disclaims any and all warranties and liabilities of any kind, including without limitation, warranties of non-infringement of intellectual property rights of any third party.

Information

For further information on technology, delivery terms and conditions and prices, please contact the nearest Infineon Technologies Office (www.infineon.com).

Warnings

Due to technical requirements, components may contain dangerous substances. For information on the types in question, please contact the nearest Infineon Technologies Office.

Infineon Technologies components may be used in life-support devices or systems only with the express written approval of Infineon Technologies, if a failure of such components can reasonably be expected to cause the failure of that life-support device or system or to affect the safety or effectiveness of that device or system. Life support devices or systems are intended to be implanted in the human body or to support and/or maintain and sustain and/or protect human life. If they fail, it is reasonable to assume that the health of the user or other persons may be endangered.